

LED A BM-21S



- ◆ Pneumatic foot pedal activates both clamping and drilling.
- ◆ Compressed air required to operate.

Single Head Multi-Boring Machine

BM-21S Single Head Multi-Boring Machine



◆ Foldable guide bar for fences



◆ Optional—longer guide fence for large panels



◆ Readout for boring head adjustment



◆ Quick-change chucks





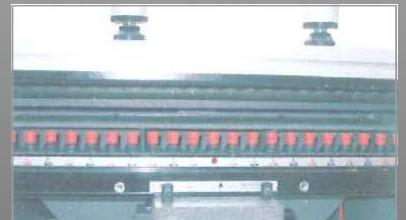

◆ Boring unit pneumatically tiltable to 45° or other angles

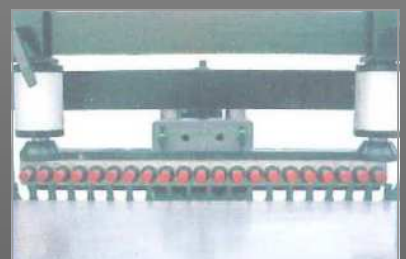

◆ Boring unit pneumatically tiltable vertical to horizontal

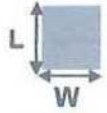

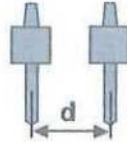
◆ Boring unit pneumatically tiltable from 90° from vertical to horizon-

MODEL	BM21S
	230V~,50Hz,1500W 400V,3~,50Hz,1500W
	LxW=890x625mm
	D=50mm
	2840rpm
	d=32mm 21pcs
	1000x1000x1100mm 20pcs/20'
	360/380KGS